

# キーおよびキー溝のJIS、旧JIS対照表

ウォーム減速機

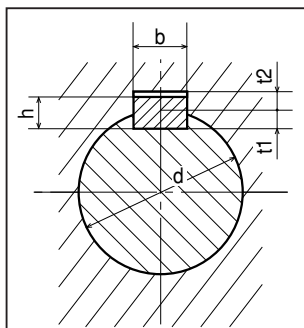

対応する 軸径 d	JISB1301-1996			旧JIS (JISB1301-1959)		
	呼び寸法 b×h	t1の 基準寸法	t2の 基準寸法	呼び寸法 b×h	t1の 基準寸法	t2の 基準寸法
10~12	4×4	2.5	1.8	4×4	2.5	1.5
12~17	5×5	3.0	2.3	5×5	3.0	2.0
17~22	6×6	3.5	2.8	—	—	—
22~25	(7×7)	4.0	3.0	7×7	4.0	3.0
22~30	8×7	4.0	3.3	—	—	—
30~38	10×8	5.0	3.3	10×8	4.5	3.5
38~44	12×8	5.0	3.3	12×8	4.5	3.5
44~50	14×9	5.5	3.8	—	—	—
50~55	(15×10)	5.0	5.0	15×10	5.0	5.0
50~58	16×10	6.0	4.3	—	—	—
58~65	18×11	7.0	4.4	18×12	6.0	6.0
65~75	20×12	7.5	4.9	20×13	7.0	6.0
75~85	22×14	9.0	5.4	—	—	—
80~90	(24×16)	8.0	8.0	24×16	8.0	8.0
85~95	25×14	9.0	5.4	—	—	—
95~110	28×16	10.0	6.4	28×18	9.0	9.0
110~130	32×18	11.0	7.4	32×20	10.0	10.0
125~140	(35×22)	11.0	11.0	35×22	11.0	11.0
130~150	36×20	12.0	8.4	—	—	—
140~160	(38×24)	12.0	12.0	38×24	12.0	12.0
150~170	40×22	13.0	9.4	—	—	—
160~180	(42×26)	13.0	13.0	42×26	13.0	13.0